



ENERGY STAR® QUALIFIED

Power Vent Water Heaters

GSW ENERGY STAR® Power Vent gas water heaters have been engineered to provide the highest energy efficiency ratings for a water heater of its kind in the market today. The reliable and trouble-free operation of the GSW Power Vent will provide hot water and peace of mind for years to come.

SAVE MONEY ON ENERGY COSTS

- ENERGY STAR® qualified (except 60 & 75 gallon models)
- Up to a 0.70 Energy Factor
- Factory-installed heat traps on the water inlet and outlet reduce the amount of heat lost through piping
- 2" CFC-free foam insulation to improve energy efficiency
- Exceeds NRCan energy efficiency standards

DESIGNED FOR PERFORMANCE

- Available for natural gas or propane
- Exclusive TankSaver® design to prolong tank life
- Suitable for elevations up to 10,100 ft. (3,078 m)
- Maximum working pressure: 150 psi

KEEPING YOU SAFE

- Sensor detects flammable vapours and automatically disables the unit preventing their ignition
- Robust air intake snorkel inhibits flammable vapours from entering the combustion chamber

EASY TO INSTALL AND MAINTAIN

- Ideal as a replacement water heater in a variety of applications due the 3-position rotatable blower
- Convenient 3/4" side taps for combination applications on 50 USG high-input and 75 USG models
- State-of-the-art electronic gas control features advanced self-diagnostic capability that makes troubleshooting easy
- Conveniently located T&P and drain valve

FLEXIBLE VENTING CONFIGURATIONS

- Can be vented with 2", 3" or 4" ULC S636 PVC, CPVC or polypropylene pipe up to 180 equivalent feet (see installation manual for full details)

LIMITED TANK AND PARTS WARRANTY

- Consult written warranty on the back of this sheet, with documentation included with water heater or contact GSW for complete warranty information

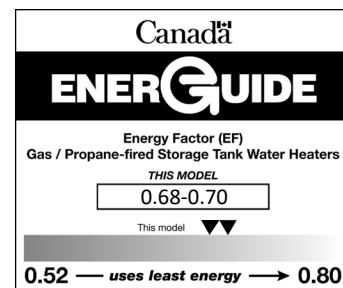



ENERGY STAR® QUALIFIED

Power Vent Water Heaters

PERFORMANCE

Tank Warranty	Model	Series	Capacity	Input	Maximum Certified Altitude	Recovery Rate at 90°F Temperature Rise	First Hour Rating	Energy Factor	BC/ON Compliant
Years**			USG (L)	BTU/h	FT (M)	GPH (LPH)	GPH (LPH)		
NATURAL GAS									
6	G640S40N-PV-ES2	200	40 (151)	40,000	10,100 (3,078)	44 (167)	73 (276)	0.70	✓
6	G640T50N-PV-ES2	200	40 (151)	50,000	10,100 (3,078)	50 (189)	90 (341)	0.70	✓
6	G650S40N-PV-ES2	200	50 (189)	40,000	10,100 (3,078)	44 (167)	90 (341)	0.70	✓
6	G650T50N-PV-ES2	200	50 (189)	50,000	10,100 (3,078)	50 (189)	96 (363)	0.70	✓
6	G650S62N-PV-ES2	200	50 (189)	62,000	10,100 (3,078)	69 (261)	110 (416)	0.70	✓
6	G660S42N-PV-ES2	200	60 (227)	42,000	10,100 (3,078)	46 (174)	106 (401)	0.70	✓
6	G675T72N-PV-ES2	300	75 (284)	72,000	10,100 (3,078)	80 (303)	155 (587)	0.68	✓

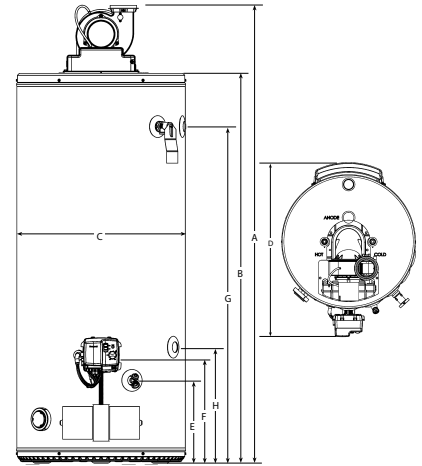

For propane models sub N for P. Natural gas models are series 200/300. Propane models are series 201/301.
 **In residential applications. Reduced warranty in commercial applications. Parts warranted for 1 year.

DIMENSIONS & SHIPPING WEIGHT

Model	Installation Height	Height to Top of Tank	Tank Diameter	Overall Depth	Height to Drain Valve	Height to Gas Inlet	Height to T&P	Height to Upper Side Connection	Height to Lower Side Connection	Shipping Weight
	A IN (CM)	B IN (CM)	C IN (CM)	D IN (CM)	E IN (CM)	F IN (CM)	G IN (CM)	G IN (CM)	H IN (CM)	LB (KG)
G640S40N-PV-ES2	59 (150)	49 ½ (126)	22 (56)	29 ½ (74)	11 (28)	13 ¼ (34)	42 ½ (108)	N/A	N/A	174 (79)
G640T50N-PV-ES2	68 ½ (174)	59 ¼ (150)	20 (51)	27 ½ (69)	11 (28)	13 ¼ (34)	53 ½ (135)	N/A	N/A	176 (80)
G650S40N-PV-ES2	60 ½ (153)	50 ¾ (129)	24 (61)	31 ½ (79)	11 (28)	13 ¼ (34)	43 ¾ (111)	N/A	N/A	198 (90)
G650T50N-PV-ES2	68 ½ (173)	58 ¾ (149)	22 (56)	29 ½ (74)	11 (28)	13 ¼ (34)	51 ¾ (131)	N/A	N/A	192 (87)
G650S62N-PV-ES2*	61 ½ (155)	52 (132)	24 (61)	31 ½ (79)	11 (28)	13 ¼ (34)	44 ½ (113)	44 ½ (113)	15 ¼ (39)	212 (96)
G660S42N-PV-ES2	67 ¼ (171)	57 ¾ (147)	24 (61)	31 ½ (79)	11 (28)	13 ¼ (34)	50 ¾ (128)	N/A	N/A	216 (98)
G675T72N-PV-ES2*	70 ¾ (179)	61 ¼ (156)	26 (66)	33 ½ (84)	11 (28)	13 ¼ (34)	53 (135)	53 (135)	15 ¼ (39)	277 (126)

* Model has side connections

PREFERRED INSTALLATION

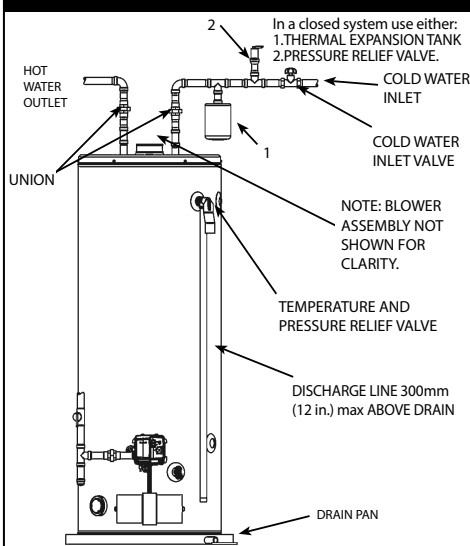

VENT PIPE LENGTHS

Model	Vent Pipe Diameter IN	Minimum Number of Elbows Required*	Maximum Vent Length with one 90° Elbow FT (M)	Minimum Vent Length with one 90° Elbow FT (M)
G640S40N-PV-ES2	2	0	50 (15.2)	7 (2.1)
G640T50N-PV-ES2				
G650S40N-PV-ES2				
G650T50N-PV-ES2	3	0	125 (38.1)	50 (15.2)
G660S42N-PV-ES2				
G650S62N-PV-ES2	4	0	180 (54.9)	125 (38.1)
G675T72N-PV-ES2				

* Refer to installation manual for further details.

VENT KITS

Description	Part Number
3" Vent Kit Includes coupling for blower outlet and termination screens	100112701
4" Vent Termination Kit Includes termination screens	100112700